

Pressure Transmitter Model ECO-1

WIKA Data Sheet PE 81.14



Applications

- Mechanical engineering
- Hydraulics
- General industrial applications

Special Features

- Pressure ranges from 0 ... 1 bar to 0 ... 1000 bar
- Current or voltage output signals
- Case and wetted parts of stainless steel
- Medium temperature -40 °C ... +100 °C
- Wiring with L-connector or flying leads



Fig. Pressure Transmitter ECO-1

Description

Wide range of applications

The pressure transmitter model ECO-TRONIC[®] has been designed for all fields of industrial pressure measurement. Typical applications are in mechanical engineering, plant construction and automation industry as well as in the refrigeration and air conditioning industry.

Reliable measurement technology

Pressure ranges from 0 ... 1 bar up to 0 ... 1000 bar cover the measuring ranges of the most applications. The sensors made by WIKA, with high accuracy, long-term stability and repeatability, have been well established in industrial pressure measurement for decades. Depending on the pressure range, the suitable sensor, either piezoresistive or metallic thin film, will be utilized.

Reliable signal acquisition

With various standard output signals like 4 ... 20 mA (2-wire), or 0 ... 10 V, 1 ... 5 V and 1 ... 6 V (3-wire), the transmitter can be easily integrated into different systems. RFI/EMI-characteristics according to EN 61 326 guarantee signal integrity even under difficult environmental conditions.

Interesting price/performance ratio

The excellent performance characteristics and the good price/performance ratio of the ECO-TRONIC make it the perfect choice for applications with medium and large volumes.

Specifications

Model ECO-1

Pressure ranges	bar	1	1.6	2.5	4	6	10	16	25
Over pressure safety	bar	5	10	10	17	35	35	80	50
Burst pressure	bar	6	12	12	20,5	42	42	96	80
Pressure ranges	bar	40	60	100	160	250	400	600	1000
Over pressure safety	bar	80	120	200	320	500	800	1200	1500
Burst pressure	bar	200	300	500	800	1250	1300	1800	3000
{Absolute pressure: 0 ... 1 bar abs to 0 ... 16 bar abs}									
Materials									
■ Wetted parts									Stainless steel
■ Case									Stainless steel
Internal transmission fluid ¹⁾									Synthetic oil
¹⁾ Not for models with pressure ranges > 16 bar									
Power supply U _B	U _B in DC V	10 < U _B ≤ 30 (14 ... 30 with output signal 0 ... 10 V, 1 ... 6 V)							
Signal output and		4 ... 20 mA, 2- wire R _A ≤ (U _B - 10 V) / 0.02 A							
Maximum load R _A	R _A in Ohm	0 ... 10 V, 3- wire R _A > 10000							
		1 ... 5 V, 3- wire R _A > 5000							
		1 ... 6 V, 3- wire R _A > 6000							
Response time (10 ... 90 %)	ms	≤ 5 (≤ 10 ms at medium temperature < -30 °C for pressure ranges up to 16 bar)							
Dielectric strength	DC V	500 ²⁾							
²⁾ NEC Class 02 power supply (low voltage and low current max. 100 VA even under fault conditions).									
Accuracy	% of span	≤ 0.5 (BFSL)							
	% of span	≤ 1.0 ³⁾							
³⁾ Including non-linearity, hysteresis, non-repeatability, zero point and full scale error (corresponds to error of measurement per IEC 61298-2). Adjusted in vertical mounting position with lower pressure connection.									
Non-linearity	% of span	≤ 0.4 (BFSL) according to IEC 61298-2							
1-year stability	% of span	≤ 0.3 (at reference conditions)							
Permissible temperature of									
■ Medium ⁴⁾		-40 ... +100 °C				-40 ... +212 °F			
■ Ambient ⁴⁾		-30 ... + 80 °C				-22 ... +176 °F			
■ Storage ⁴⁾		-30 ... +100 °C				-22 ... +212 °F			
Compensated temp range		0 ... + 80 °C				32 ... + 176 °F			
⁴⁾ Also complies with EN 50178, Tab. 7, Operation (C) 4K4H, Storage (D) 1K4, Transport (E) 2K3									
Temperature coefficients within compensated temp range									
■ Mean TC of zero	% of span	≤ 0.4 / 10 K							
■ Mean TC of range	% of span	≤ 0.3 / 10 K							
CE- conformity		89/336/EEG interference emission and immunity see EN 61 326							
		Interference emission limit class A and B							
		97/23/EG Pressure equipment directive							
Wiring protection		Protected against reverse polarity and short circuiting on the instrument side							
Weight	kg	Approx. 0.15							

{ } Items in curved brackets are optional extras for additional price.

Dimensions in mm

Ingress Protection IP per IEC 60 529

L-connector
DIN EN 175301-803, Form A
for conductor cross section up to
max. 1.5 mm²,
conductor outer diameter 6 to 8 mm
IP 65
Order code: A4

Circular connector
M 12x1, 4-pin
IP65
Order code: M4

Flying leads with 1.5 m of cable,
conductor cross section 0.5 mm²,
AWG 20 with end splices,
conductor outer diameter 6.6 mm,
IP67
Order code: DL

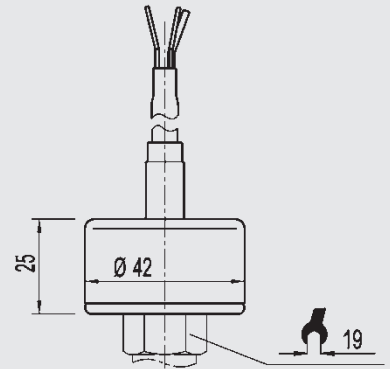
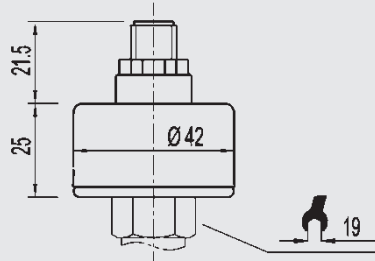
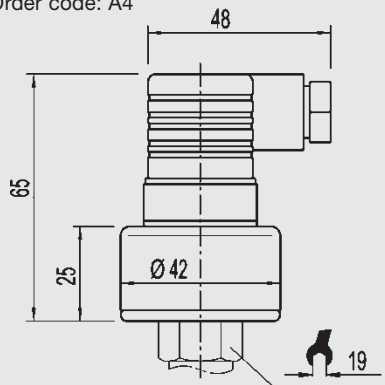

Pressure connections

G 1/4
EN 837
Order code: GB

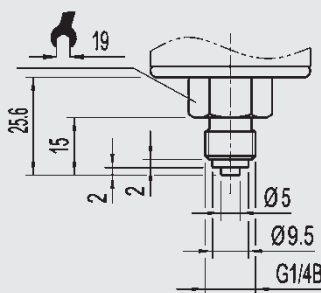

1/4 NPT
per „Nominal size for US standard
tapered pipe thread NPT“
Order code: NB

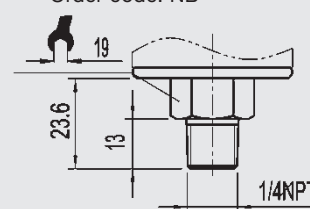

Others on request

For installation and safety instructions see the operating instructions for this product.

For tapped holes and welding sockets please see Technical Information IN 00.14 for download at www.wika.de -Service

Wiring details

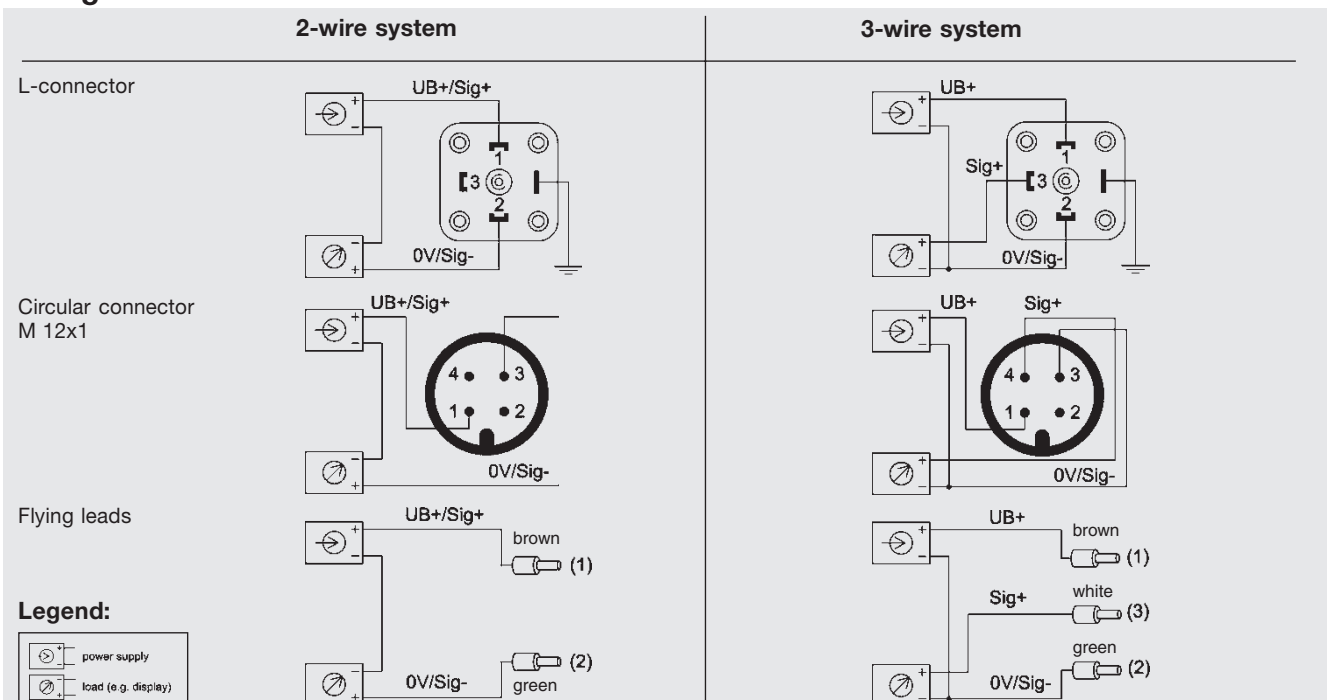

" # ' #)



!"# \$ % & ' () * + , - . / : ;

!"# \$ % & ' () * + , - . / : ;

802 % 0 ') / 9 / 02 / 9 2 + 6 // 444 5

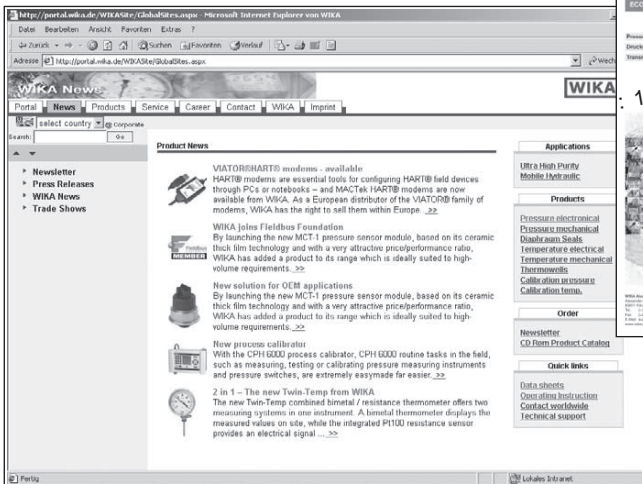

1 2 2 / ' / / 6 / / 1 / / ' 1 . 2 / '(5 1 2 //12 '(% 1 2 % (/ 4 0 1 2

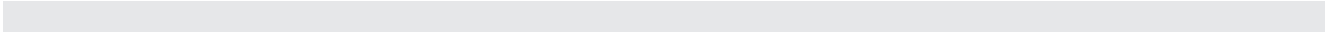

! " # \$ % & ' () * + , - . / 0 1 1 2 3 4 5